THE GENIE-P FOR SAMPLING OF HAZARDOUS LIQUIDS IN A HAZARDOUS AREA

Refineries, Chemical Plants, Drug Manufacturers and indeed many other industries discharge effluent which is composed of a mixture of explosive chemicals, or emit an explosive vapour.

With normal effluent discharges from industry, sampling is a simple matter with either portable or free-standing samplers, and as sampling is the means whereby the water authorities or the industries themselves, are able to determine the degree to which the effluents have been polluted; it is virtually impossible where the effluents contain chemicals emitting a hazardous (explosive) vapour. It is with this in mind that SIRCO™ Controls Limited has developed a Sampling System called the **GENIE-P**, for use in hazardous areas and for taking samples which themselves emit a hazardous vapour. Classified Division 'O' the **GENIE-P** is a two part Sampler with a Control Unit (safe area) and the Sampling Unit (hazardous area).

A Patent has been granted for the GENIE-P Sampler under Patent No. 2 243 823.

The connection between the Sampling Unit and the Control Unit is a cluster umbilical carrying pneumatic and/or intrinsically safe signals. The only requirement at the Control Unit in the Safe Area being a suitable air supply and a 110/230 vac electrical input.

The SIRCO™ **GENIE-P** Sampler is microprocessor based and features great flexibility in both the programming and operational function fields, and can take samples either using the Vacuum/Pressure method of sampling (**GENIE-P or GENIE-P/VBV version**), or from a Pressurised Source using the SIRCO™ Overflow method (**GENIE-P/O version**).

The Programming flexibility is enhanced by the use of a **REAL-TIME** clock, enabling the actual desired day, date and time to be entered (to the nearest minute), in parameters such as **DELAY**, **START** and **END TIME**. The interval between samples is selectable from 1 minute to 24 hours, in 1 minute increments with the time that the next sample is due to be taken being displayed.

SAMPLING PROGRAMMES

A total of four sampling programmes are available – one factory set programme – and three programmes which the user may set. These may be set to regularly used sequences in order to facilitate rapid on site installation and operation.

Also, a **REVIEW** facility is provided, so that the parameters set in any programme can easily be checked.

Included as standard are facilities for operating from external equipment, such as a Flow Monitor. These consist of an **EXTERNAL TRIGGER**, which will accept a contact closure or open collector transistor output, and a 4-20 mA signal input.



Sampling Unit

MCERTS CERTIFICATION

Both the **GENIE-P** and the **GENIE-P/VBV** versions of this Sampler conform to the Mcerts Performance Standards for Continuous Water Monitoring Systems, Part 1, Version 2 (Oct 2006).

REMOTE CONTROL AND PROGRAMMING

GENIE-P Samplers are fitted with an RS232C interface, allowing communication between the Sampler Controller and a computer which has serial communications software (such as Windows Terminal) installed. The protocol used is simple two-wire and ground. The facility gives full remote control via the computer keyboard, including program and interrogate functions.

A 7 way weatherproof auxiliary connector is provided on the side of the control unit allowing connection to a computer.

SPECIFICATIONS

Each unit is housed in a robust GRP cabinet, the Sampling Unit being free-standing, and the Control Unit wall mounted.

CONTROL UNIT

CONTROLLER OPERATION

The SIRCO™ **GENIE** Controller is a Microprocessor based unit with a 40 character x 4 line Liquid Crystal Display and 16 Tactile Keys with audible data entry.

The Controller is fitted with Lithium Batteries which are used to run the Real-Time clock and to retain programme data when the unit is off.

EX-T INPUTS

When the controller is set in the EX-T mode it can receive negative going pulses from external equipment. This requires the EX-T input to be grounded by the external equipment, using either a volt free contact closure from a relay or by sinking the voltage on the input of the controller using a transistor. When the EX-T counter is set to 1, the controller will operate the sampler each time it receives a negative going pulse. When set to 2 or more the counter will decrement each time it receives a negative going pulse until it reaches zero, when the controller will operate the sampler.

4-20mA INPUTS

When the controller is set in the EX-T mode and the 4-20mA option switched on, it can also receive a 4-20mA analogue signal from external equipment. When a 4-20mA signal is received the EX-T counter will count down from the user set number to zero. The speed of the counter and therefore the sampling frequency will be proportional to the mA input signal.

EX-T MODE DISPLAY

When the programmer is operating in the EX-T mode a typical display format would consist of the real time display and battery state indicator on the top line, as in the timer mode display. On the second line the display will show the number of the next sample to be taken and the EX-T pulse counter. This counter will count down from the EX-T counter number programmed in by the user, reset and initiate a sampling sequence upon reaching zero.

DISPLAY LANGUAGE

The readout for the Liquid Crystal Display is available in six languages as standard; other languages can be programmed in at the factory, if required.

The Six Standard Languages are:

- ✓ ENGLISH
- ✓ FRANCAIS
- ✓ ITALIANO
- ✓ DEUTSCH
- ✓ ESPANOL
- ✓ NEDERLANDS

This will normally be factory set if requested at the time of order, but can be programmed by the user as and when required.

SAMPLING UNIT

SAMPLE CONTAINER OPTIONS

The GENIE-P Sampler can be supplied as either a Discrete or Composite Sampler, and has a removable 24 Jar shelf. For Discrete Sampling options we can offer 24 x 500ml, 24 x 1 litre or 4 x 2 litre Sample Bottles. For Composite Sampling options we can offer various sizes of Composite Container from 5 to 25 litres.

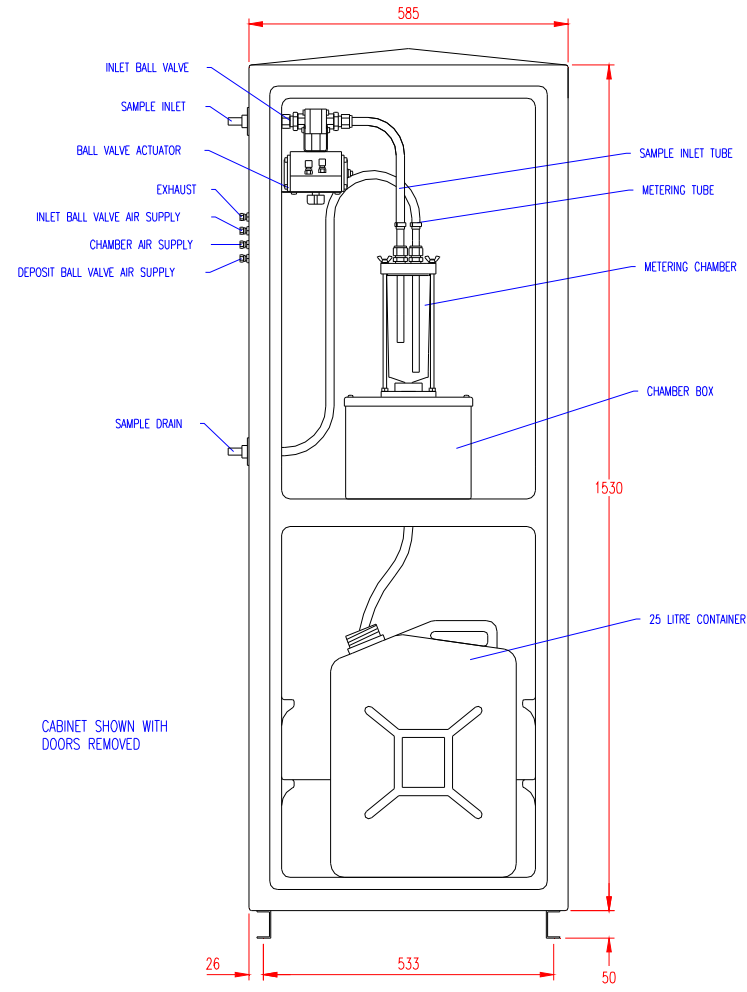

CABINET SHOWN WITH DOORS REMOVED

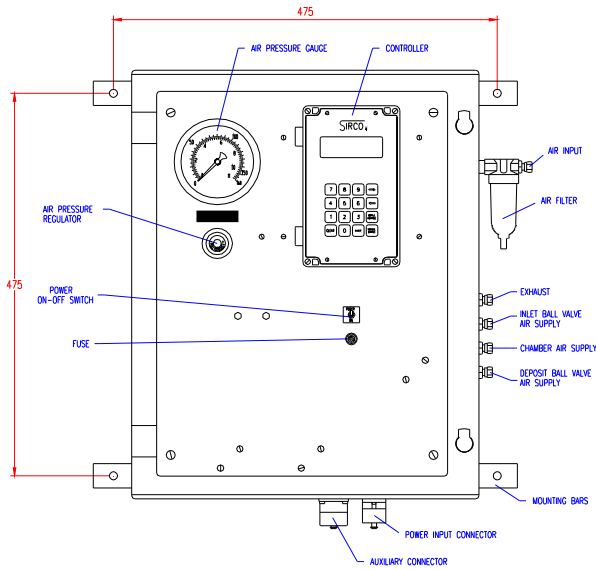

CABINET DIMENSIONS: 532 x 430 x 200 (H x W x D)

SIRCO™ CONTROLS LIMITED
SWEYNES INDUSTRIAL ESTATE
ASHINGDON ROAD
ROCHFORD
ESSEX
SS4 1RQ

Tel: +44 (0)1702 545125
Email: info@sirco-controls.co.uk

